

## ENGINE - K SERIES KV6

### Camshaft timing belt

12.65.18

#### Remove

1. Disconnect battery earth lead.
2. Remove ancillary drive belt.

 **CHARGING AND STARTING, REPAIRS, Ancillary drive belt - KV6.**

3. Remove RH front road wheel.

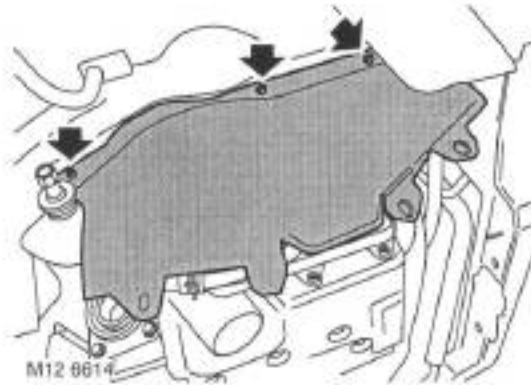

4. Remove 3 bolts securing RH splash shield to body and remove shield.

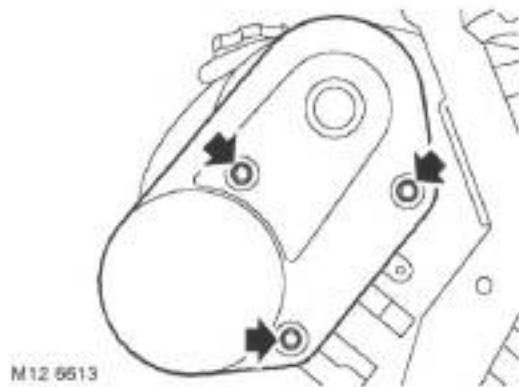

5. Remove 3 bolts securing camshaft timing belt LH rear cover and remove cover.
6. Remove inlet manifold chamber.

 **MANIFOLDS & EXHAUST SYSTEMS - K SERIES KV6, REPAIRS, Seals - inlet manifold chamber - up to 03MY.**

 **MANIFOLDS & EXHAUST SYSTEMS - K SERIES KV6, REPAIRS, Seals - inlet manifold chamber - from 03MY.**

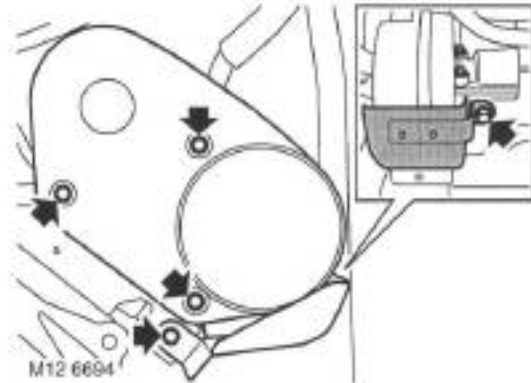

7. Remove 2 bolts securing RH rear timing belt cover heat shield; remove heat shield.
8. Remove 3 bolts securing RH rear timing belt cover; remove cover.

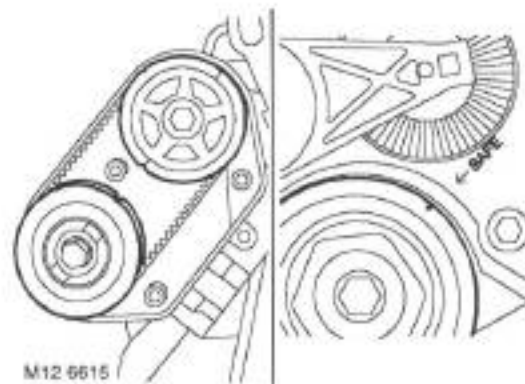

9. Using a socket on crankshaft pulley bolt, rotate crankshaft in a clockwise direction. Align the engine 'SAFE' position, notch on crankshaft pulley with the 'ARROW' on front mounting plate and the timing marks aligned on the rear camshaft gears as illustrated.

**CAUTION: Do not use camshaft gear bolts or timing belt to rotate crankshaft.**

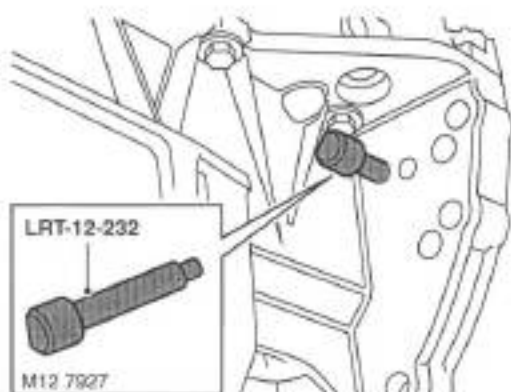

10. Insert timing pin **LRT-12-232** through hole in lower crankcase, ensuring pin is located in hole in drive plate.

**CAUTION:** Hole immediately adjacent to side of lower crankcase must be used.

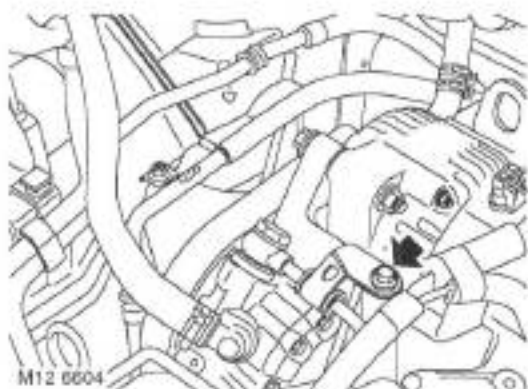

11. Remove bolt securing PAS pipe to engine front mounting plate.

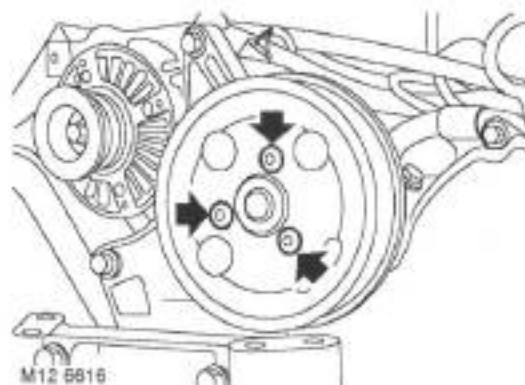

12. Remove 3 Torx screws securing PAS pump pulley and remove pulley.

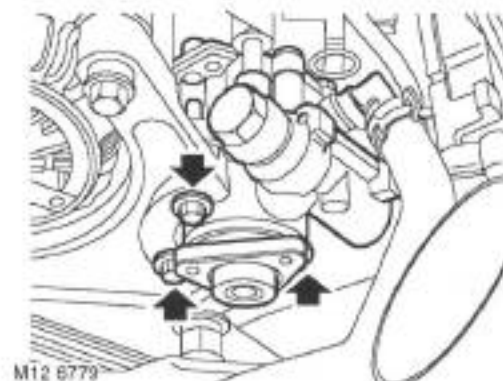

13. Remove 3 bolts securing PAS pump to front mounting plate and tie pump aside.

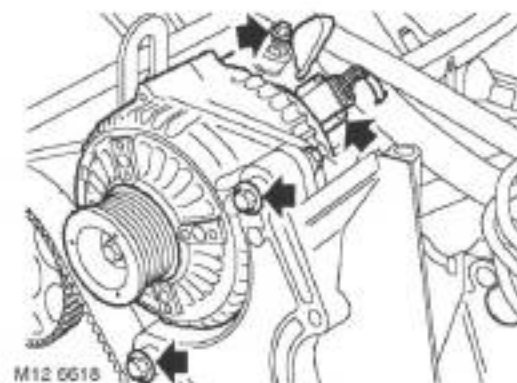

14. Release alternator battery lead terminal cover, loosen terminal nut and disconnect lead from terminal.
15. Disconnect multiplug from alternator.

## ENGINE - K SERIES KV6

---

16. Remove lower bolt and upper nut and bolt securing alternator to front mounting plate.
17. Remove alternator.

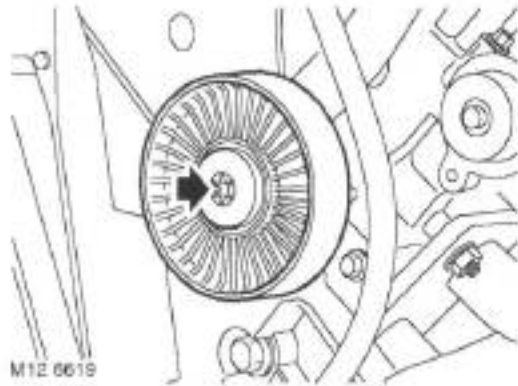

18. Remove Torx screw securing idler pulley to front mounting plate and remove pulley.

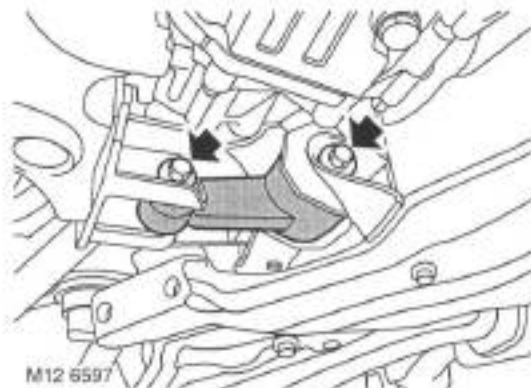

19. Loosen bolt securing lower engine steady to front subframe.
20. Remove bolt securing lower engine steady to sump mounting, release lower engine steady from sump mounting.



21. Remove 3 bolts securing camshaft timing belt RH front cover and remove cover.

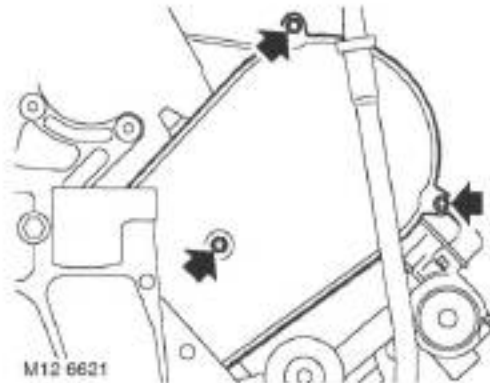

22. Remove 3 bolts securing camshaft timing belt LH front cover and remove cover.
23. Assemble LRT-12-161 to LRT-12-199 and secure with clamp bolt.

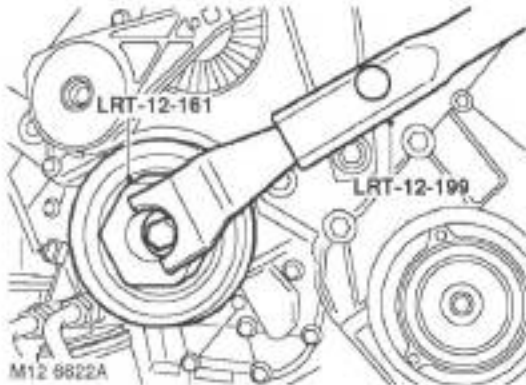

24. Insert LRT-12-161 with LRT-12-199 into crankshaft pulley, loosen and remove pulley bolt.

**CAUTION:** Ensure crankshaft does not rotate during above operation.

25. Remove tools LRT-12-161 and LRT-12-199 from crankshaft pulley, remove pulley.

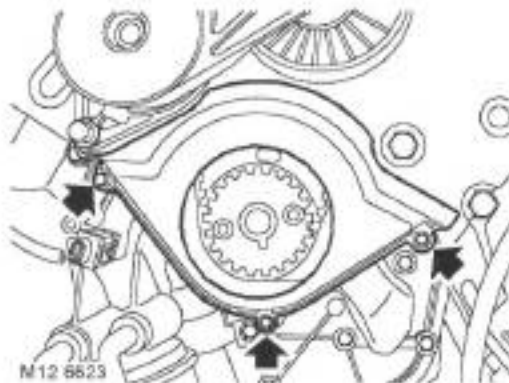

26. Remove 3 bolts securing camshaft timing belt lower cover to cylinder block and remove cover.

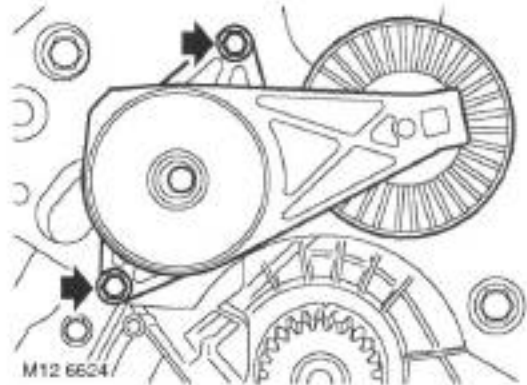

27. Remove 2 bolts securing ancillary drive belt tensioner and remove tensioner.

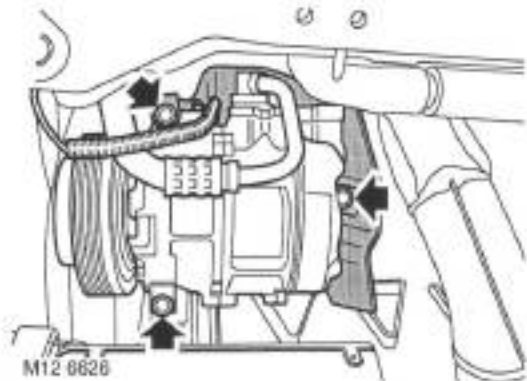

28. Note fitted position of heat shield on A/C compressor and remove 3 bolts securing A/C compressor to front mounting plate and cylinder block. Release A/C compressor and heat shield and position aside.

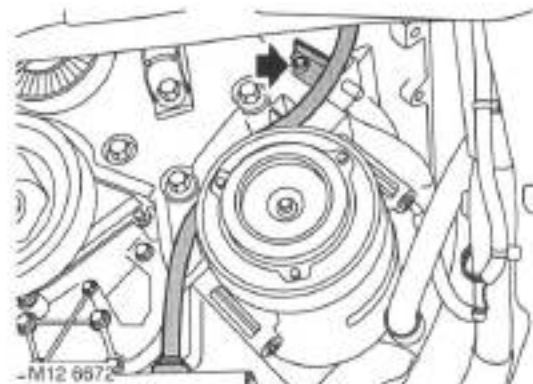

29. Remove bolt securing dipstick tube to cylinder block.

## ENGINE - K SERIES KV6

30. Depress and hold down dipstick tube locking collar, remove dipstick tube from engine sump.

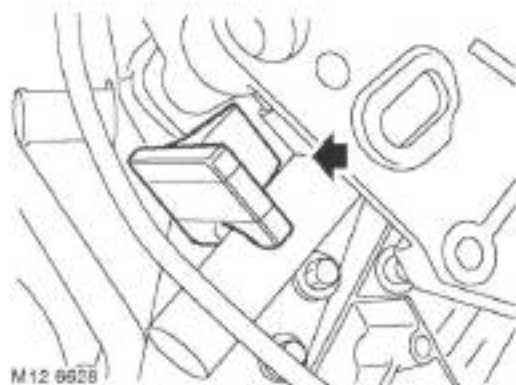

31. Remove rubber blanking plug from around camshaft timing belt tensioner.

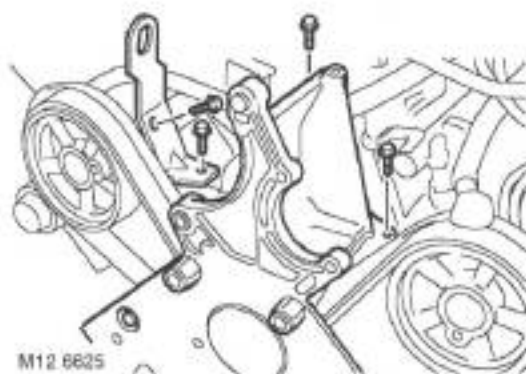

32. Remove 3 bolts securing engine front mounting plate and lifting bracket to cylinder block.
33. Remove bolt securing lifting bracket to RH cylinder head and remove lifting bracket.

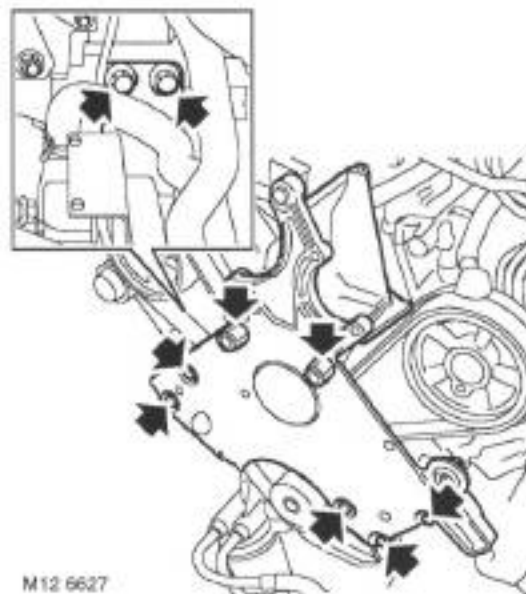

34. Remove 2 bolts securing IRD support bracket to engine front mounting plate.
35. Remove 5 bolts and 2 pillar bolts securing engine front mounting plate to cylinder block.
36. With care, release and remove front mounting plate from engine.

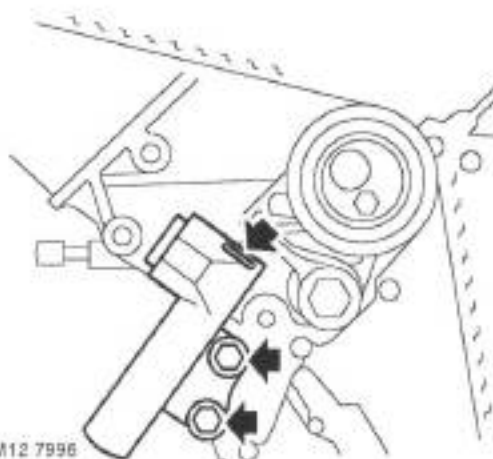

37. Insert a suitable 1.5 mm diameter pin through hole in tensioner body and into hole in plunger.
- NOTE: If holes in body and plunger are not aligned, move tensioner backplate using a suitable broad bladed screwdriver; this will move plunger sufficiently to enable pin to be inserted.*



38. Remove and discard 2 Patchlok bolts securing tensioner to cylinder block and remove tensioner.

**CAUTION:** Exercise great care when removing bolts, do not apply excessive torque. If bolts appear to be seized, apply suitable anti-seize lubricant prior to removing bolts. **DO NOT** loosen Allen screw securing tensioner pulley.

39. If camshaft timing belt is to be refitted, mark direction of rotation on timing belt before removal.
40. With care, ease camshaft timing belt from gears using fingers only and remove timing belt.

**CAUTION:** Do not rotate crankshaft or camshafts with timing belt removed and cylinder heads fitted.

**CAUTION:** Camshaft timing belt must be replaced if cylinder head is to be removed or new drive gears, tensioner or coolant pump are to be fitted. Camshaft timing belts must be stored and handled with care. Always store a camshaft timing belt on its edge with a bend radius greater than 50 mm (2.0 in). Do not use a camshaft timing belt that has been twisted or bent double as this will damage the reinforcing fibres. Do not use a camshaft timing belt if debris other than belt dust is found in timing belt covers. Do not use a camshaft timing belt if partial engine seizure has occurred. Do not use a camshaft timing belt if mileage exceeds 72,000 km (45,000 miles). Do not use an oil or coolant contaminated timing belt, cause of contamination must be rectified.

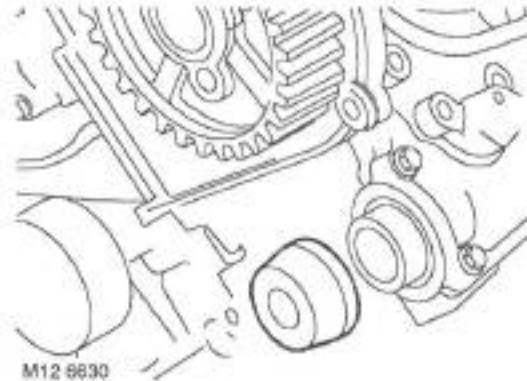

41. Remove and discard LH and RH exhaust camshaft cap seals.

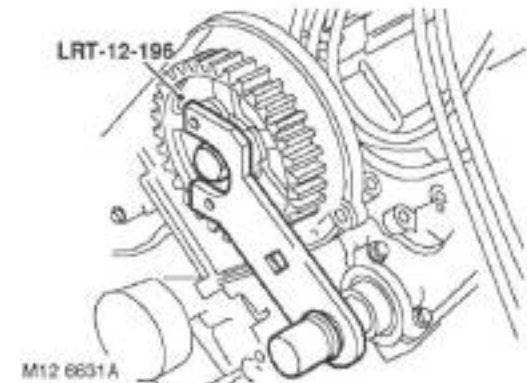

42. Position tools **LRT-12-196** to LH and RH front inlet camshaft gears and into the end of each exhaust camshaft.
- CAUTION:** Special tools must be fitted when tightening or loosening gear retaining bolts, otherwise damage to camshafts may occur.
43. Remove and discard bolts retaining front inlet camshaft gears to camshafts.
44. Remove tools **LRT-12-196** from both inlet camshaft gears and exhaust camshafts.
45. Remove camshaft drive gears and hub assemblies.



## ENGINE - K SERIES KV6

### Refit

**NOTE:** Following front or rear timing belt refitment, it is possible that, after rotating the engine and positioning the crankshaft pulley to the 'SAFE' position, the timing marks on the rear timing gears may be misaligned. This misalignment is acceptable provided that the timing belt refitting procedure was carried out correctly.

1. Clean camshaft gears and hubs, crankshaft gear, tensioner and water pump pulleys.  
**CAUTION:** If the sintered gears have been subjected to prolonged oil contamination, they must be soaked in a solvent bath and then thoroughly washed in clean solvent before refitting. Because of the porous construction of sintered material, oil impregnated in the gears will emerge and contaminate the belt.
2. Fit hubs to camshaft gears and fit gears to camshafts. Fit new bolts and tighten sufficiently to allow gears to rotate without tipping.
3. Position timing belt to crankshaft gear.  
**NOTE:** To prevent the timing belt from disengaging from the crankshaft gear when fitting, fit a suitable wedge between the belt and oil pump belt guard.

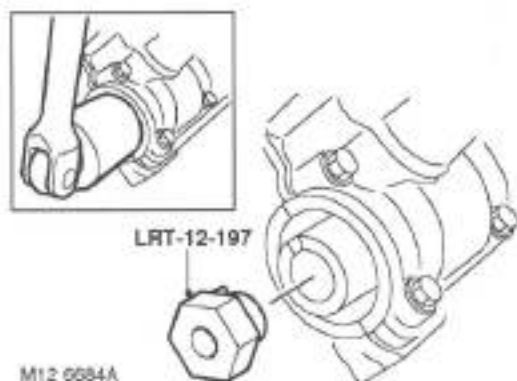

4. Fit tool LRT-12-197 into each exhaust camshaft in turn.

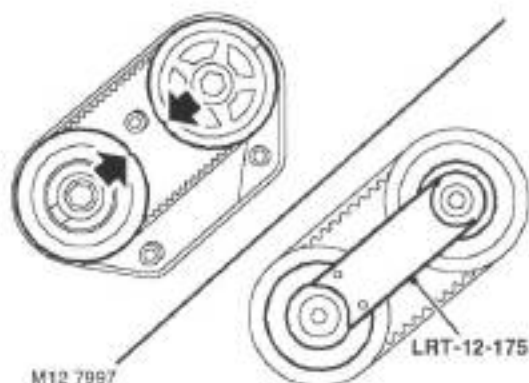

5. Using assistance, rotate each exhaust camshaft slightly and align timing marks on LH and RH rear camshaft gears.
6. Remove tool LRT-12-197 from exhaust camshaft.
7. Fit tools LRT-12-175 to LH and RH rear camshaft gears.
8. Rotate both front inlet camshaft gears fully clockwise as viewed from front of engine.
9. Using fingers only, fit timing belt to gears, starting at the crankshaft gear and working in an anti-clockwise direction, keeping the belt run as taut as possible and turning the camshaft gears only a minimum amount anti-clockwise to fit timing belt.

**CAUTION:** Gears must not be rotated anti-clockwise more than one tooth.

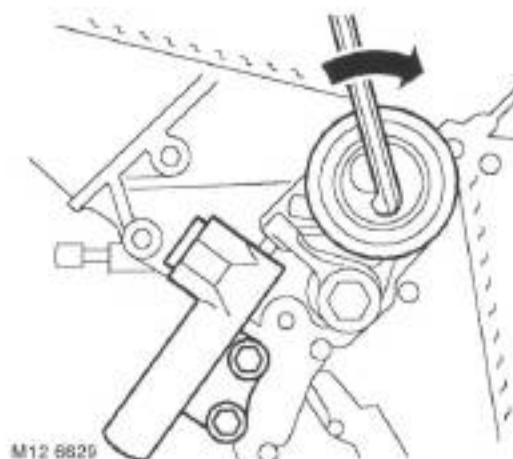

10. Position an Allen key in tensioner backplate and hold tensioner pulley against timing belt.



11. With assistance, position tensioner, fit new Patchlok bolts and tighten to 25 Nm (18 lbf.ft).  
**CAUTION: Ensure tensioner plunger is contacting underside of tensioner backplate.**

12. Remove tools **LRT-12-175** from rear timing belt gears.

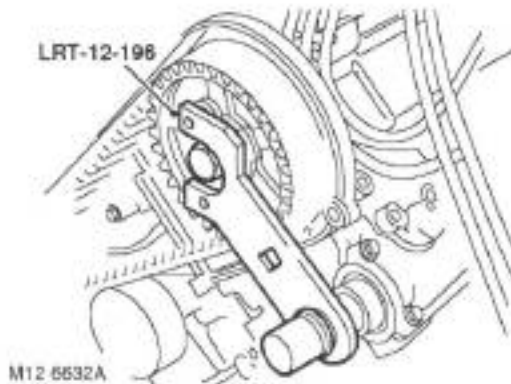

13. Fit tools **LRT-12-196** to both front inlet camshaft gears and into the end of each exhaust camshaft.  
**CAUTION: Special tools must be fitted when tightening or loosening gear retaining bolts, otherwise damage to camshafts may occur.**



14. Tighten front inlet camshaft gear bolts to:  
 ● Stage 1 - 27 Nm (20 lbf.ft)  
 ● Stage 2 - Further 90°
15. Remove tools **LRT-12-196** from both inlet camshaft gears and exhaust camshafts.
16. Remove wedge from between drive belt and oil pump belt guard.
17. Remove 1.5 mm diameter pin from tensioner.
18. Fit rubber blanking plug around tensioner.
19. Remove timing pin **LRT-12-232**.
20. Clean exhaust camshaft front cap seal locations and fit new cap seals.  
**CAUTION: The sealing edge of the cap seal and mating face must be clean and dry.**
21. Position engine front mounting plate and manoeuvre plate into position. Fit bolts but do not tighten at this stage.



22. Fit bolts securing IRD support bracket to front mounting plate but do not tighten at this stage.
23. Tighten bolts in the sequence shown:  
 ● Bolt No. 1 - 25 Nm (18 lbf.ft)  
 ● Bolt No. 5 - 45 Nm (33 lbf.ft)  
 ● Bolts Nos. 2, 3, 4, 6 and 7 - 85 Nm (63 lbf.ft)
24. Position engine lifting bracket, fit bolts securing lifting bracket and front mounting plate to cylinder block and RH cylinder head. Tighten M10 bolts to 45 Nm (33 lbf.ft) and M8 bolt to 25 Nm (18 lbf.ft).
25. Clean end of dipstick tube.
26. Position dipstick tube to sump and cylinder block, fit bolt and tighten to 9 Nm (7 lbf.ft).
27. Position A/C compressor to front mounting plate and cylinder block, align heat shield, fit and tighten bolts to 25 Nm (18 lbf.ft).
28. Clean lower timing belt cover.
29. Position lower timing belt cover, fit and tighten bolts to 9 Nm (7 lbf.ft).
30. Clean crankshaft pulley.
31. Fit crankshaft pulley to crankshaft gear and ensure that the indent on pulley locates over the lug on crankshaft gear.
32. Fit crankshaft pulley bolt and washer, position **LRT-12-161** with **LRT-12-199** into crankshaft pulley. Tighten pulley bolt to 160 Nm (118 lbf.ft).
33. Remove tools **LRT-12-161** and **LRT-12-199** from crankshaft pulley.
34. Clean ancillary drive belt tensioner.
35. Position ancillary belt tensioner, fit bolts and tighten to 25 Nm (18 lbf.ft).
36. Clean LH and RH front timing belt covers.
37. Position LH and RH front timing belt covers, fit and tighten bolts to 4 Nm (3 lbf.ft).
38. Clean idler pulley, position pulley to engine front mounting plate and tighten Allen bolt to 45 Nm (33 lbf.ft).
39. Position alternator to front mounting plate.



## ENGINE - K SERIES KV6

40. Fit bolt and nut and bolt securing alternator to front mounting plate and tighten to 45 Nm (33 lbf.ft).
41. Connect alternator multiplug.
42. Connect battery lead to alternator, fit and tighten nut to 8 Nm (6 lbf.ft), fit terminal cover.
43. Position PAS pump to front mounting plate, fit and tighten bolts to 25 Nm (18 lbf.ft).
44. Position PAS pipe to engine front mounting plate, fit and tighten bolt to 25 Nm (18 lbf.ft).
45. Clean PAS pump pulley mating faces.
46. Position PAS pump pulley, fit and tighten Torx screws to 9 Nm (7 lbf.ft).
47. Position lower engine steady to sump mounting, fit and tighten bolt to 100 Nm (74 lbf.ft).
48. Tighten bolt securing lower engine steady to subframe to 100 Nm (74 lbf.ft).
49. Clean LH rear timing belt cover.
50. Position LH rear timing belt cover, fit and tighten bolts to 4 Nm (3 lbf.ft).
51. Clean RH rear timing belt cover.
52. position RH rear timing belt cover, fit bolts and tighten to 4 Nm (3 lbf.ft).
53. Position heat shield, fit bolts and tighten M6 bolt to 9 Nm (7 lbf.ft) and M8 bolt to 25 Nm (18 lbf.ft).
54. Fit inlet manifold chamber.  
 **MANIFOLDS & EXHAUST SYSTEMS - K SERIES KV6, REPAIRS, Seals - inlet manifold chamber - up to 03MY.**  
 **MANIFOLDS & EXHAUST SYSTEMS - K SERIES KV6, REPAIRS, Seals - inlet manifold chamber - from 03MY.**
55. Fit RH road wheel and tighten nuts to 115 Nm (85 lbf.ft).
56. Fit ancillary drive belt.  
 **CHARGING AND STARTING, REPAIRS, Ancillary drive belt - KV6.**

### Camshaft timing belt cover - RH front

 12.65.39

#### Remove

1. Disconnect battery earth lead.
2. Remove ancillary drive belt.  
 **CHARGING AND STARTING, REPAIRS, Ancillary drive belt - KV6.**

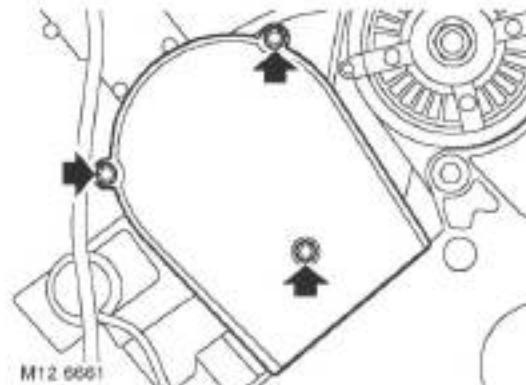

3. Remove 3 bolts securing camshaft timing belt RH front cover and remove cover.

#### Refit

1. Clean RH front timing belt cover.
2. Position RH front timing belt cover, fit and tighten bolts to 4 Nm (3 lbf.ft).
3. Fit ancillary drive belt.  
 **CHARGING AND STARTING, REPAIRS, Ancillary drive belt - KV6.**
4. Connect battery earth lead.

  
**SEE  
PDF**