

TIL. No.	Part No.	Description	Qty. Rqd.
----------	----------	-------------	-----------

REAR SUSPENSION

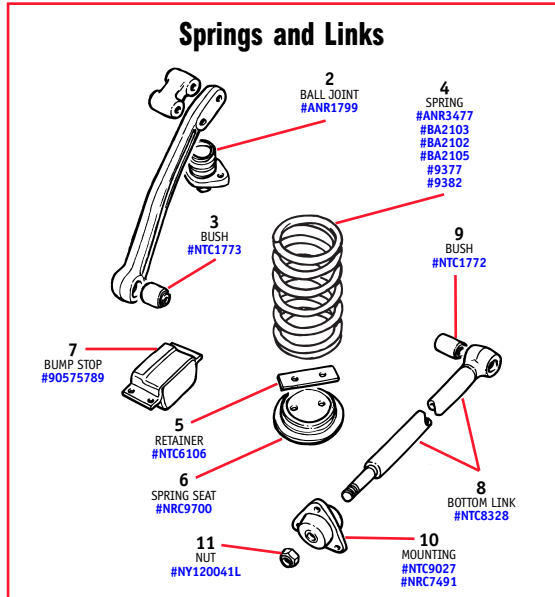

1
POLYBUSH KIT
#9776



Springs and Links

- | | | | |
|----|--------------------|---|---|
| 1 | 9776 | POLYBUSH KIT, REAR SUSPENSION TOP LINK | 1 |
| 2 | ANR1799 | BALL JOINT, rear suspension top link | 1 |
| 3 | NTC1773 | BUSH, rear suspension top link | 2 |
| 4 | ANR3477
BA2103 | COIL SPRING, rear, standard | 2 |
| | BA2102 | COIL SPRINGS, rear, heavy duty, 240lbs, pair
<i>Spring height of 413mm</i> | 1 |
| | BA2102 | COIL SPRINGS, rear, extra heavy duty, 295lbs, pair
<i>Spring height of 445mm</i> | 1 |
| | BA2105 | COIL SPRING, rear, heavy duty, pair | 1 |
| | 9377 | COIL SPRING, rear, medium duty, OME, each | 2 |
| | 9382 | COIL SPRING, rear, heavy duty, OME, each | 2 |
| 5 | NTC6106 | RETAINER, coil spring | 2 |
| 6 | NRC9700 | SEAT, coil spring | 2 |
| 7 | 90575789 | BUMP STOP, rubber | 2 |
| 8 | NTC8328 | BOTTOM LINK ASSEMBLY | 2 |
| 9 | NTC1772 | BUSH, bottom link | 2 |
| 10 | NTC9027
NRC7491 | MOUNTING, flexible, bottom link to chassis | 2 |
| | | MOUNTING, flexible, bottom link to chassis
<i>Alternative to NTC9027</i> | 2 |
| 11 | NY120041L | NUT, mounting to bottom link | 2 |

PRICES SUBJECT TO CHANGE.
Call for the Latest Pricing and Availability.

TIL. No.	Part No.	Description	Qty. Rqd.
----------	----------	-------------	-----------



12
SHOCK KIT
#9272
#9278



16
TWIN SHOCK FITTING KIT
#BA2159

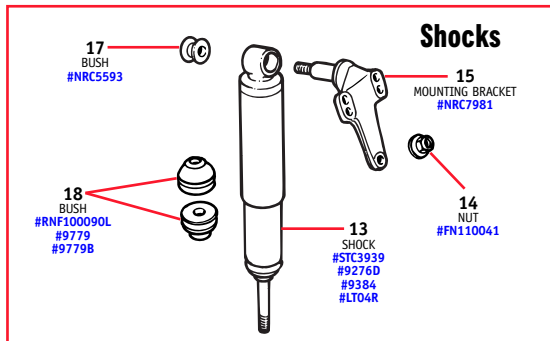

Shocks

- | | | | |
|----|--------------------|--|---|
| 12 | 9272 | REAR SHOCK KIT, pair, standard | 1 |
| | 9278 | REAR SHOCK KIT, pair, Bilstein | 1 |
| 13 | STC3939 | SHOCK ASSEMBLY, rear, standard | 2 |
| | 9276D | SHOCK ASSEMBLY, rear, Bilstein | 2 |
| | 9384 | SHOCK ASSEMBLY, rear, OME Gas filled | 2 |
| | LTR04R | SHOCK ASSEMBLY, rear, ARB Long Travel Remote type | 2 |
| 14 | FN110041 | NUT, flanged, rear shock mounting bracket | 6 |
| 15 | NRC7981 | MOUNTING BRACKET, rear shock | 2 |
| 16 | BA2159 | TWIN SHOCK FITTING KIT, rear
<i>Includes brackets and fixings required to fit twin rear shock absorbers</i> | 1 |
| 17 | NRC5593 | BUSH, upper, rear shock | 2 |
| 18 | RNF100090L
9779 | BUSH, lower, rear shock | 4 |
| | 9779B | SHOCK BUSH KIT, rear, axle set, red polybushes | 1 |
| | 9779B | SHOCK BUSH KIT, rear, axle set, blue polybushes
<i>Softer than red polybushes</i> | 1 |



19
ANTI-ROLL BAR KIT
#9216
#BA034A

- | | | | |
|----|--------|---|---|
| 19 | 9216 | ANTI-ROLL BAR KIT, rear, heavy duty
<i>Includes bar and fittings</i> | 1 |
| | BA034A | ANTI-ROLL BAR KIT, rear, standard
<i>Includes bar and fittings</i> | 1 |

TIL. No.	Part No.	Description	Qty. Rqd.
----------	----------	-------------	-----------

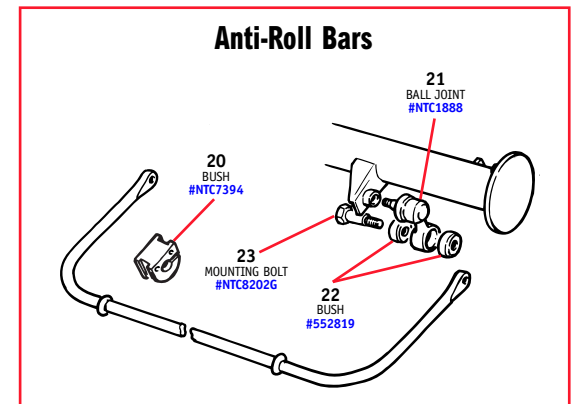

Anti-Roll Bars

- | | | | |
|----|----------|---|---|
| 20 | NTC7394 | BUSH, anti-roll bar mounting, rear | 2 |
| 21 | NTC1888 | BALL JOINT ASSEMBLY, anti-roll bar | 2 |
| 22 | 552819 | BUSH, ball joint | 4 |
| 23 | NTC8202G | MOUNTING BOLT, ball joint, Genuine
<i>(sway bar link bolt)</i> | 2 |



24
AIR LIFT 1000 KIT
#9263

- | | | | |
|----|------|--|---|
| 24 | 9263 | AIR BAG SYSTEM, Air Lift 1000
<i>Increases rear load capacity</i> | 1 |
|----|------|--|---|

TECH TIP: Bilstein Shock Upgrades



The rubber bushings on earlier Bilstein shocks were more than adequate for the rigors of off-roading, but not always tough enough for the air wrench of an over-zealous mechanic. Bilstein has since buffed up their bushings with thicker, stronger rubber so even the burliest mechanic won't harm them. It is important, however, that you match the proper set of Bilsteins to your Discovery. The Disco I has a differently shaped mount, so be sure to specify your Discovery model when ordering.



TO ORDER, CALL **1-800-533-2210**