



1DQ/1DR/1DS – Additional Fitting Instructions

Range Rover & Sport (L405 & L494) + Land Rover Discovery V (L462)



1DQ (L405) / 1DR (L494 Sport/L462 Disco V) Front Upper Wishbone Bushes:

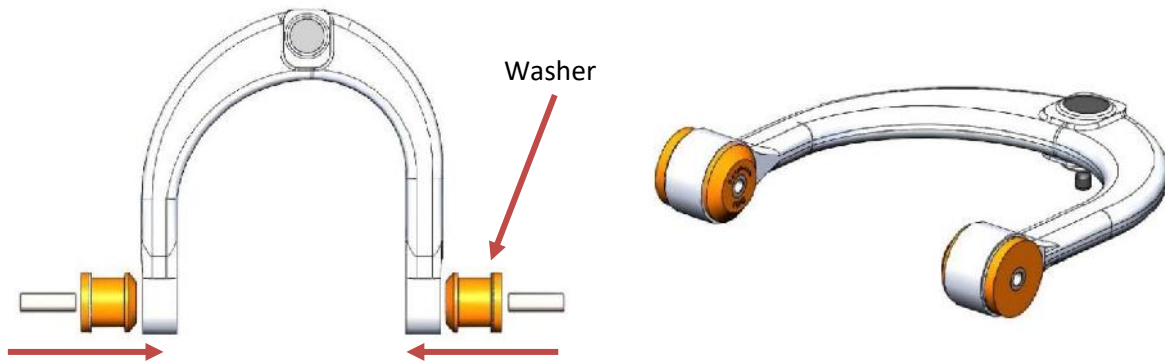

Note: Polybushes should be fitted to both upper suspension arms on both sides of the vehicle.

- The control arms must be correctly supported and the new 1DQ (L405) or 1DR (L494 Sport L462 Disco V) Polybushes pressed into the arm housings with strict reference to the diagram above (**The steel washer MUST be on the outside of the eye section**).
- The polyurethane bush should be inserted first followed by the metal tube.
- A lubricant that can dry up very quickly such as tyre soap or washing up liquid will be more than sufficient in assisting with installing your new Polybushes.
- Refit the control arms to the vehicle taking special care to tightening the bolts back up with the arms held at 90 degrees which will allow for maximum camber offset.

1DS (L405/L494 Sport/L462 Disco V) - Front Lower Rear Arm Inner Bush

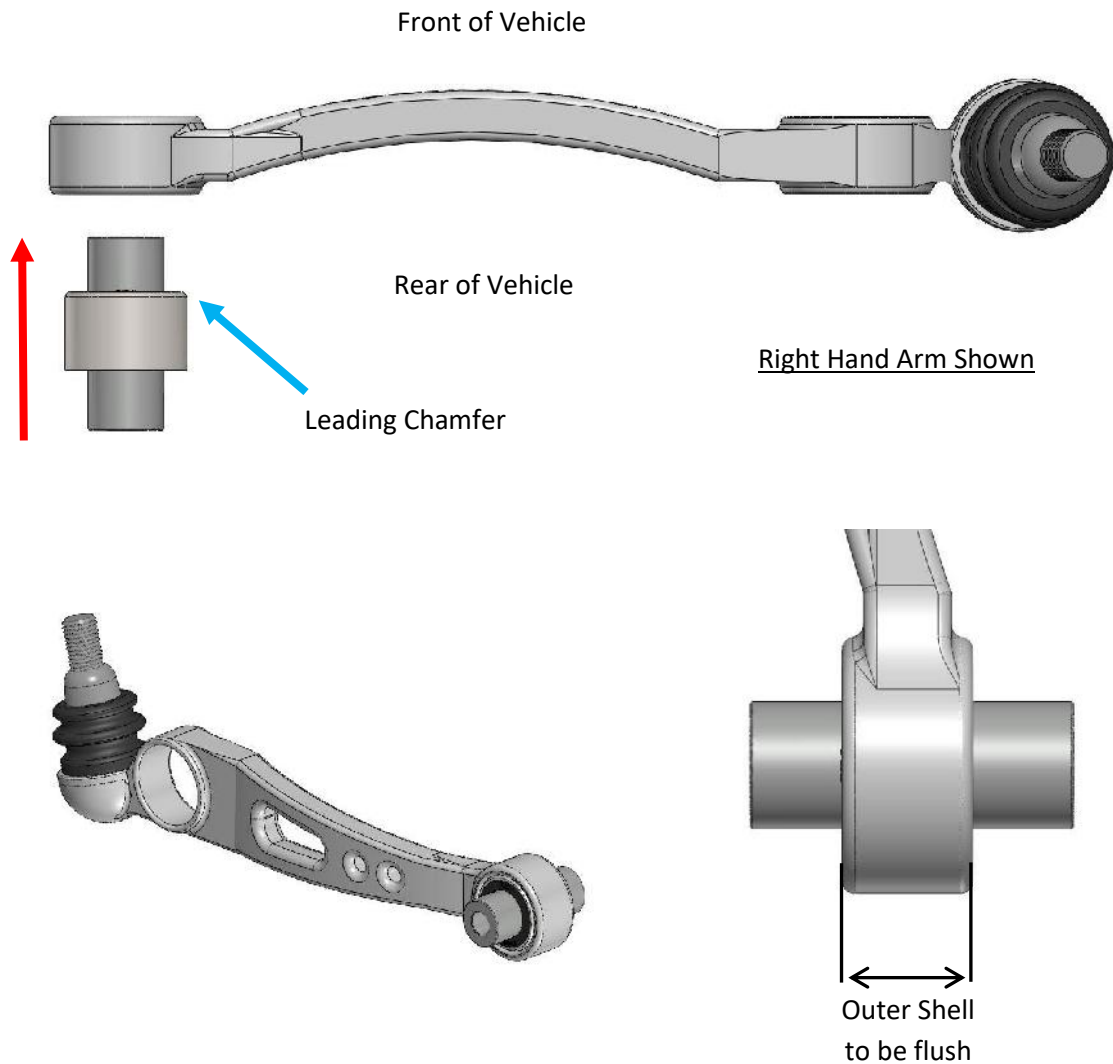

- Ensure the leading chamfer is pushed from the rear of the vehicle towards the front.
- Press the bush into the housing until the outer shell is flush with the arm.
- Refit the arms and tighten when the car is at 'standard' ride height.

If you have any questions regarding the fitment of these bushes, please give us
a ring on 01978 664316

or send us an e-mail on sales@polybush.co.uk.